

# AEROCHARGER TECHNOLOGY

In 1976, an engineer had a vision. He drew up his concept of an innovative new turbocharger—one that employed an ingenious vane mechanism, low-mass rotating assembly, and non-flooded precision ceramic bearings. This was the variable geometry turbo that became the Aerocharger. Some three and a half decades later, his brainchild remains on the forefront of innovation, being fitted for use on new applications for which conventional turbochargers are inadequate. The Aerocharger ranks as one of the most efficient turbochargers available for any application, and this means horsepower-boosting energy savings for your engine.

## 01 Variable Vane

The Variable Area Turbine Nozzle (VATN) system is an adjustable vane assembly that adjusts the flow area (A/R ratio) to perfectly match the engine's requirements from just off ideal through redline. This allows boost to be generated immediately, without the delay in power that every conventional turbo has.

The Aerocharger's integrated boost controller allows boost response to be mechanically adjusted, and this is the only turbo in the world to have this option.

What does lag free boost mean? It means no dangerous surges or jolts when control is critical, with massive horsepower and torque added right on top of your engine's stock power band.

## 02 Internal Oil Supply

Aerocharger's self-contained oiling system is highly regarded in the engineering world. Conventional automotive turbos require oil lines to be tapped and fitted. This adversely affects the vehicle's stock system, adding large amounts of heat to the oil supply and reducing pressure and flow to the engine.

The Aerocharger lubricates from an internal oil reservoir contained within the housing of the turbo. An oil wicking system draws oil from the reservoir and gradually feeds it directly to the bearing shaft, where the oil is spun into a fine mist by centrifugal force. This mist properly lubricates the entire bearing assembly without creating resistance from excessive oil.

This system is so effective that a small amount of oil can last for several years, will never

require changing, and speed and efficiency are improved while the overall weight of the turbocharger system is reduced. It has been rigorously tested and proven, and Aerochargers have exceeded a 30,000 hour operation test conducted by an international military group.

## 03 Thermal Management

The backwall of the Aerocharger is reinforced with layers of high-tech insulation. This keeps thermal energy where it belongs on the exhaust side, and away from the compressor side where the air charge is generated.

The compressor housing has a 2:1 mass advantage on the turbine side to soak up heat during a hot shutdown. This protects the bearings from the coking effect that conventional turbos suffer from.



## Self-Contained

The Aerocharger is the only turbo to use a wicking system for lubrication. Aerocharger's bearings lubricate with a fine oil mist, which enable ultra-high speed spooling that isn't possible with conventional lubrication. Other self-contained turbos use grease-packed bearings, which operate with massive drag and resistance.

## Ceramic Ball Bearings

The most modern bearing technology available. The Aerocharger's ball bearings exceeded a 30,000 hour operation test by an international military group - that's 3.4 years at full boost.

## D5S NiResist Alloy

The Aerocharger's turbine housing is constructed from an exotic D5S NiResist alloy. This premium aircraft-grade metal contains up to 38% nickel, and has advanced corrosion-resisting properties superior to stainless steel.

## Compressor Wheel

Building our own turbo gives us the data and knowledge to precisely match the compressor wheel to each application's flow requirements - a concept generally misunderstood by other turbo kit builders.

## Advanced Turbine Balancing

Aerocharger turbines are balanced to tolerances up to 20 times more precise than standard turbos. Precision balancing reduces the load the bearings have to carry while dropping the time required for the turbo to spool.

## Variable Turbine

A waste-gated turbocharger may use only 75% of the exhaust gas flow. The Aerocharger uses 100% of the exhaust, enabling it to produce the same boost with substantially less backpressure. The result is faster, more efficient boost, and offers huge advantages for backpressure-sensitive two-stroke motors.

## Turbine Heat Shield

A stainless, ceramic-coated Turbine Heat Shield reduces under-hood temperatures, while containing thermal energy for the turbine to efficiently produce boost.





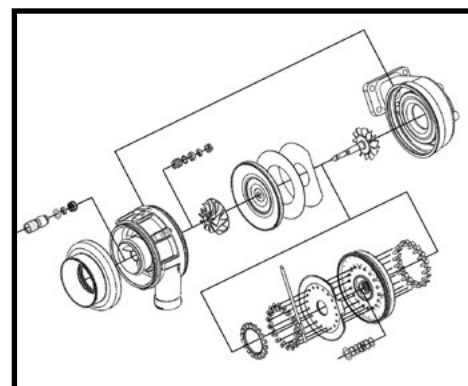
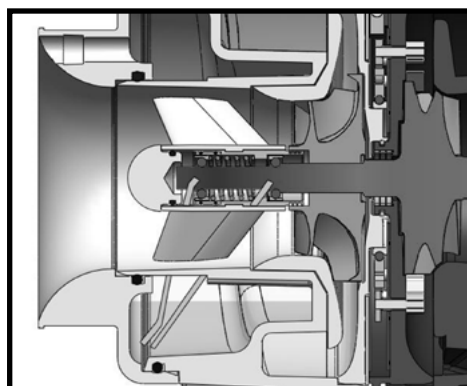
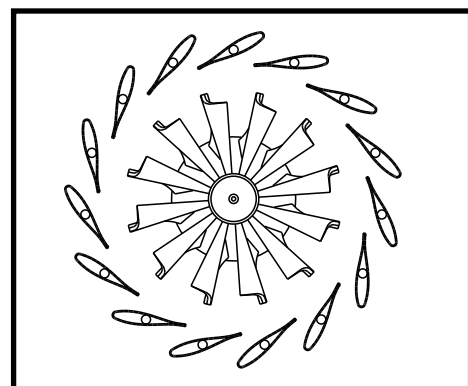

## Integrated Boost Controller

The integrated boost controller allows for the boost amount to be set. Boost response can be mechanically adjusted here, making it the only turbo in the world with this feature.



## BOOST SPRINGS

Aerocharger boost springs are used to set the boost pressure. Every Aerocharger is shipped with a green 5 PSI spring already installed. Available springs include:

5 PSI		GREEN	8 PSI		BLUE ORANGE
6 PSI		GREEN BLUE	9 PSI		ORANGE
7 PSI		BLUE	11+ PSI		BLACK



## SPRING SHIMS

Shims can be added to the springs to increase the boost in increments of about .5 to .75 PSI.

## AEROCHARGER OIL

Specialized oil for ultra-high rpm machinery. Only use genuine Aerocharger Turbo Oil. The wrong oil can lead to bearing failure.

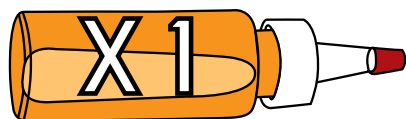

ADD 1 BOTTLE FOR 53 SERIES



ADD 2 BOTTLES FOR 66 SERIES

**NOTE: NEVER attempt to disassemble the main Aerocharger housings. The bearing and vane systems require specialized tools to take it apart without damaging it. Contact Aerocharger for all service and repairs.**

The Aerocharger is a sophisticated and highly efficient variable vane turbocharger. Unlike conventional turbos, it does not require oil pumps or lines. The Aerocharger will not need more maintenance than any other turbo - this graphic contains information for adjusting the Aerocharger to ensure best performance.

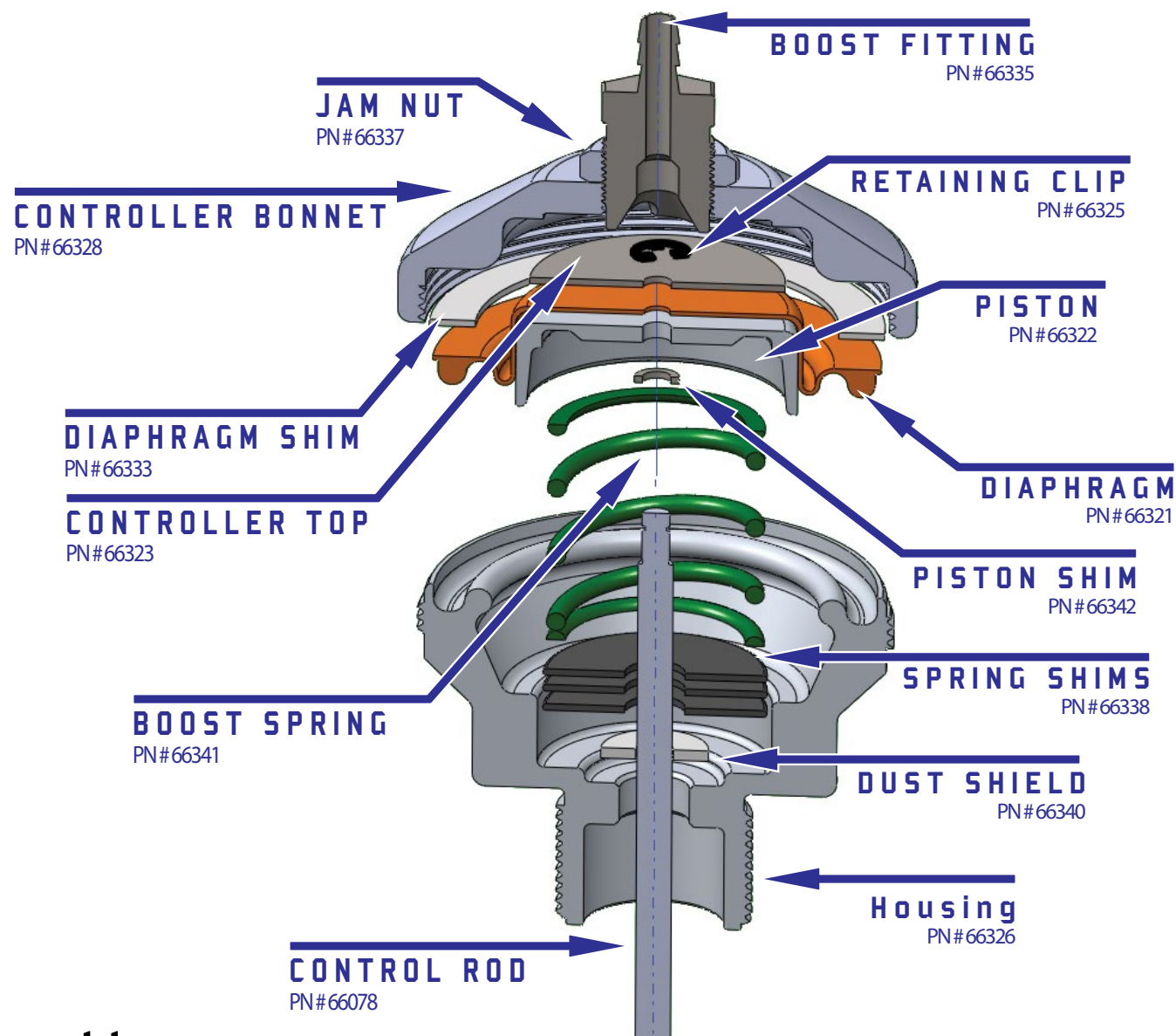

## INTEGRATED BOOST CONTROLLER

The Integrated boost controller on the Aerocharger is a simple mechanical actuator where pressure in a chamber pushes against a spring to move the vanes. It can be easily disassembled to adjust the boost by changing springs and/or shims. Manual & electronic boost controllers are compatible with Aerocharger systems, but are not recommended.

## OIL LEVELS

Aerochargers consume oil throughout their use. The amount of oil consumed is very small, and the oil level must only be checked once a year or every 30,000 miles. Aerocharger oil never has to be changed - only added. There is no benefit to changing the oil unless it has been contaminated with a foreign substance, such as if the vehicle has been underwater for a long time.



## CHECKING OIL LEVEL

Remove the fill plug and use a zip tie as a dip stick to measure the oil level.

Oil should be added if the level is lower than .5" (1.3 cm.)

Oil is full at 1" height (2.5 cm.)

Use red thread lock fluid on the threads when replacing the fill plug and tighten down securely.

## HORIZONTAL ORIENTATION

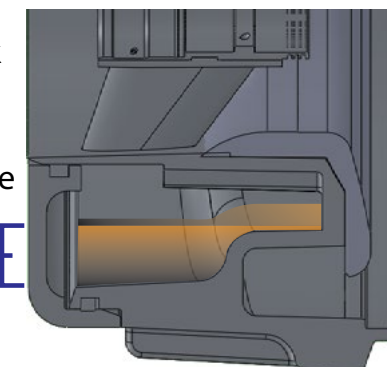

**VISIT AEROCHARGER.COM TO SEE A VIDEO TUTORIAL ABOUT ADJUSTING THE AEROCHARGER'S BOOST CONTROLLER TO AFFECT TURBO RESPONSE**